

## YP-SRT – Slip Ring testing

---

### *General*

YP-SRT system included a special test mode that measures the resistance changes (noise) that is generated in a SLIP-RING unit as a result of its rotation. The system enabled automatic noise measurement of each ring inside the slip ring including control of the rotation direction.

The slip ring testing procedure is a combination of tests. It includes the standard YP-30H testing capability and procedure with several unique and dedicated tests that are of the YP-SRT.

1. **First phase: Wiring test.** This is a stationary stage where both sides of the slip ring (Rotor & Stator) are connected to the tester. In this phase we are checking the L.V continuity, H.V insulation resistance and H.V leakage current of the Slip-Ring UUT – between the pins, chains and components, as defined and needed by the user.
2. **Second phase: Dynamic resistance test.** This is a dedicated test for slip rings. In this stage only the stator side is connected to the tester. The rotor side contacts are shorted and the rotor is rotating using an external Motor, either controlled by the tester or manually. Each ring (or set of rings, per the method of testing) should be tested during clock and counter clock -wise rotation of the rotor, in order to cover a noise measurement of the two rotation directions.

There are two different possible test modes under this category. Each mode requires different wiring configuration and the results may differ in precision, accuracy and testing time.

- Dynamic resistance (noise): The tester is using YP special measurement method to measure the noise of a SINGLE ring. At least three rings are needed in order to perform this test. This method is slower in testing time, yet is very accurate. This method is unique to the YP-SRT testing features.
- Dynamic resistance (noise pair): The tester measures the noise of several rings in serial connection. This method is faster in testing time, yet can give failure status of the full tested set only, and may be less accurate as a combination of rings may deliver passing parameters, while any member of the set may fail requirements.

To move from first stage to the second a manually intervention is required, in order to change the wiring configuration and prepare the UUT for the second phase.

Notes:

- Using a special test fixture that integrates a constant compatible slip-ring can support a complete automatic testing without any manually intervention
- Testing noise required Four Wire (4W) measurement mode connection. In this mode the tester is using two testing points (TP) for each connector's pin. The usual capability of the tester's TP (in 2 Wire tests) is divided by two.
- In order to increase the actual number of TP it is possible to use 4W connection on the stator side and 2W connection on the rotor side.
- The YP-SRT tester has an integrated option for automatic control over the currency output that enables the switching of the motor direction automatically as part of the testing procedure.
- In order to get more accurate readings while measuring a low resistance it is recommended to specify 100mA or even 500mA while defining the dynamic resistance test procedure.
- Separated wiring lists can be combined together under one project file (Functional test) with additional users remarks.

### ***Controlling the rotator motor***

To reach best testing results at an optimum time, we recommend to connect the rotator motor with the tester, so that changing the rotation after 360 degrees will be performed automatically.

The control card's output is a **Male - 25 pins** D-TYPE connector. The usage of the card's pins is described in the following table:

PINS	DIRECTION 1	DIRECTION 2
4 & 17	CLOSED	OPENED
20 & 21	CLOSED	OPENED
20 & 22	OPENED	CLOSED

Example: If you have a motor that changes its rotation direction due to a different polarity of the voltage, you should - connect the motor's power terminal to pin number 20, the positive supply voltage to pin number 21 and the negative supply voltage to pin number 22.

*Note: Maximum ratings for the motor's power supply are 28VDC/1A*

It is also possible to connect the motor as a whole to the tester, so full activation is performed from the testing program. While this is easier to operate, we must alert of some dangerous, that lays in having an external motor (sometimes rather big) being activated automatically.

## Testing modes

---

The following examples will demonstrate the different wiring connection for testing a Slip Ring Unit of 6 rings. Each example below is followed by the proper compatible wiring list.

1. Wiring test
2. Dynamic resistance (noise)
3. Dynamic resistance (noise pair) I
4. Dynamic resistance (noise pair) II

### 1] Wiring Test

Testing UUT continuity and insulation without any rotating operation. Both Slip Ring sides are connected to the tester.

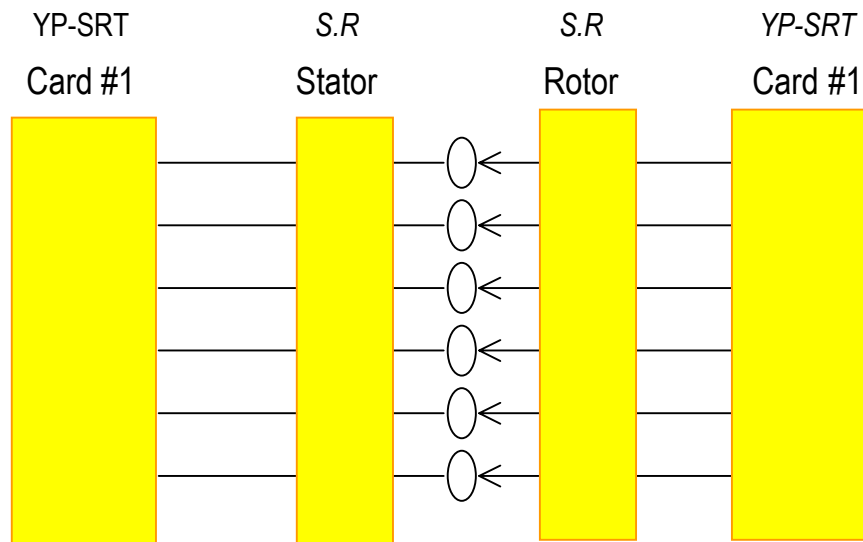

### Wiring scripts

Test Mode: - Continuity res.  
- H.V. Insulation res.  
- H.V. DC Dielectric strength  
- H.V. AC Dielectric strength

### List:

F-001-01	F-001-03	F-001-05
C-001-07	C-001-09	C-001-11
F-001-02	F-001-04	F-001-06
C-001-08	C-001-10	C-001-12

## 2] *Dynamic resistance (Noise)*

Testing the resistance noise of each ring during the rotation of the rotor

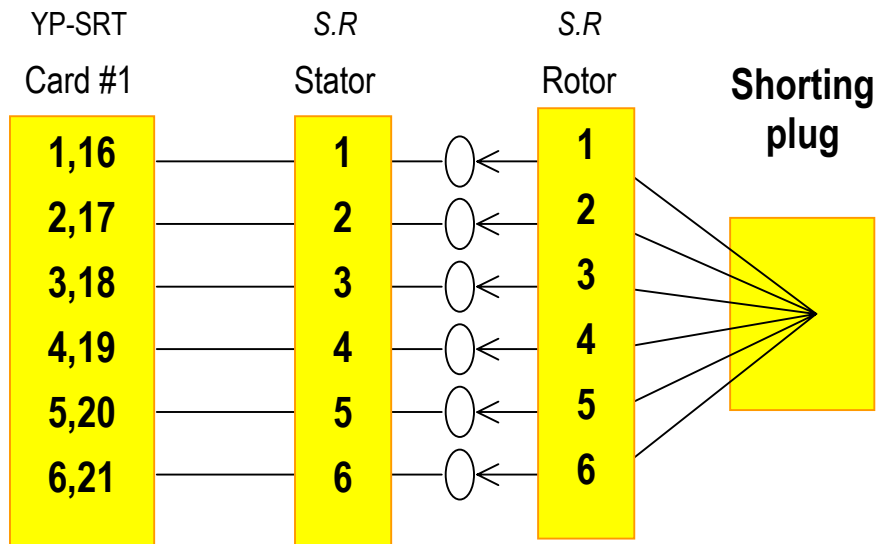

*Wiring scripts*

Test Mode: Dynamic res. (noise)

List:

- F-001-01
- F-001-02
- F-001-03
- F-001-04
- F-001-05
- F-001-06

### 3] *Dynamic resistance (Noise pair) Method I*

Testing the resistance noise of all rings in a serial connection during the rotation of the rotor.

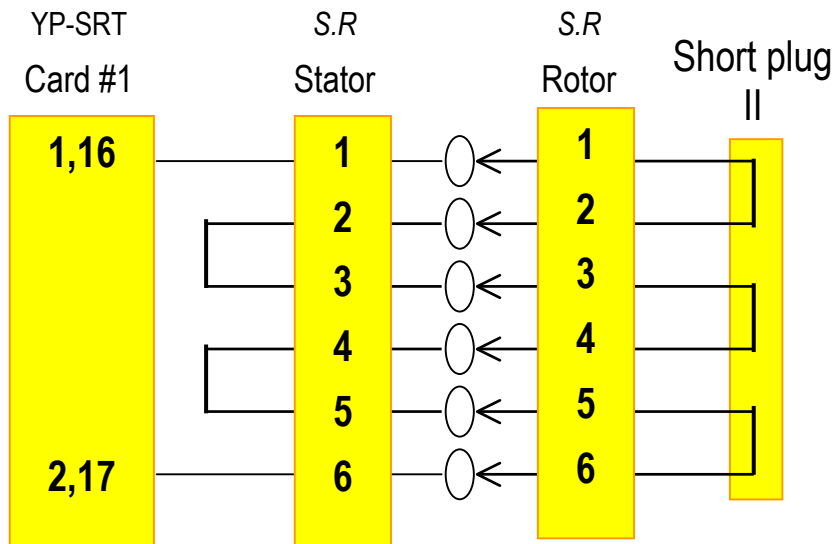

*Wiring scripts*

Test Mode: Dynamic res. (noise pair)

List:

- F-001-01
- C-001-02

#### 4] *Dynamic resistance (Noise pair) Method II*

Testing the resistance noise of each two rings in serial connection during the rotation of the rotor.

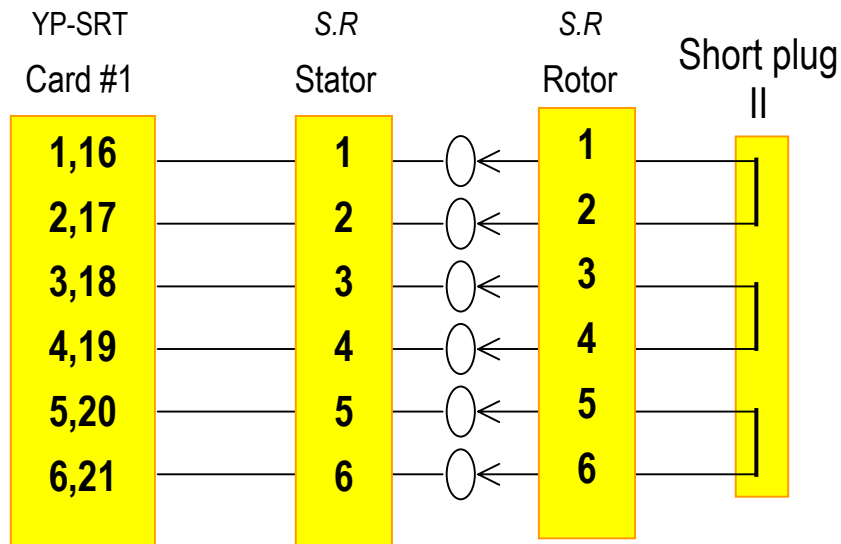

*Wiring scripts*

Test Mode: Dynamic res. (noise pair)

List:

F-001-01  
C-001-02

F-001-03  
C-001-04

F-001-05  
C-001-06